

HIGH PERFORMANCE Y-AXIS HORIZONTAL TURNING CENTERS

PUMA 2100·2600YII

PUMA 2100Y/SY/LY/LSYII

PUMA 2600Y/SY/LY/LSY/YB/SYB/LYB/LSYBII



PUMA 2100 · 2600Y II

PUMA 2100 / 2600 Y II turning centers have been redesigned to deliver even more power and precision. A comprehensive line up of machines with chuck sizes from 8” to 12”, integrated Y-axes and sub-spindles makes Puma 2100/2600Y II turning centers unrivalled and unbeatable in their performance.

CONTENTS

Product Overview

Basic Information

- 04 Machining Area
- 05 Spindle
- 06 Turret
- 07 Tailstock

Detailed Information

- 08 Standard / Optional Specifications
- 09 Peripheral Equipment
- 10 FANUC i PLUS
- 12 SIEMENS S828D
- 13 Power | Torque
- 16 External Dimensions
- 17 Machine Specifications

Customer Support Service

- 19 Customer Support and Services
- 19 Global Network



HIGH RIGIDITY AND PRECISION



The turning centres have a rigid and stable structure which helps eliminate vibrations and ensure high accuracy machining and improved process reliability.

HIGH PERFORMANCE Y-AXIS FOR COMPLEX MACHINING



All machines in the range feature powerful, high torque spindles which, in conjunction with their Y-axis capabilities, enables them to machine high-precision, complex parts in fewer set ups.

IMPROVED USER CONVENIENCE



The EZ work, with its hot keys and a range of user-friendly functions enable fast, trouble-free job set ups and efficient and reliable monitoring and management.



MACHINING AREA

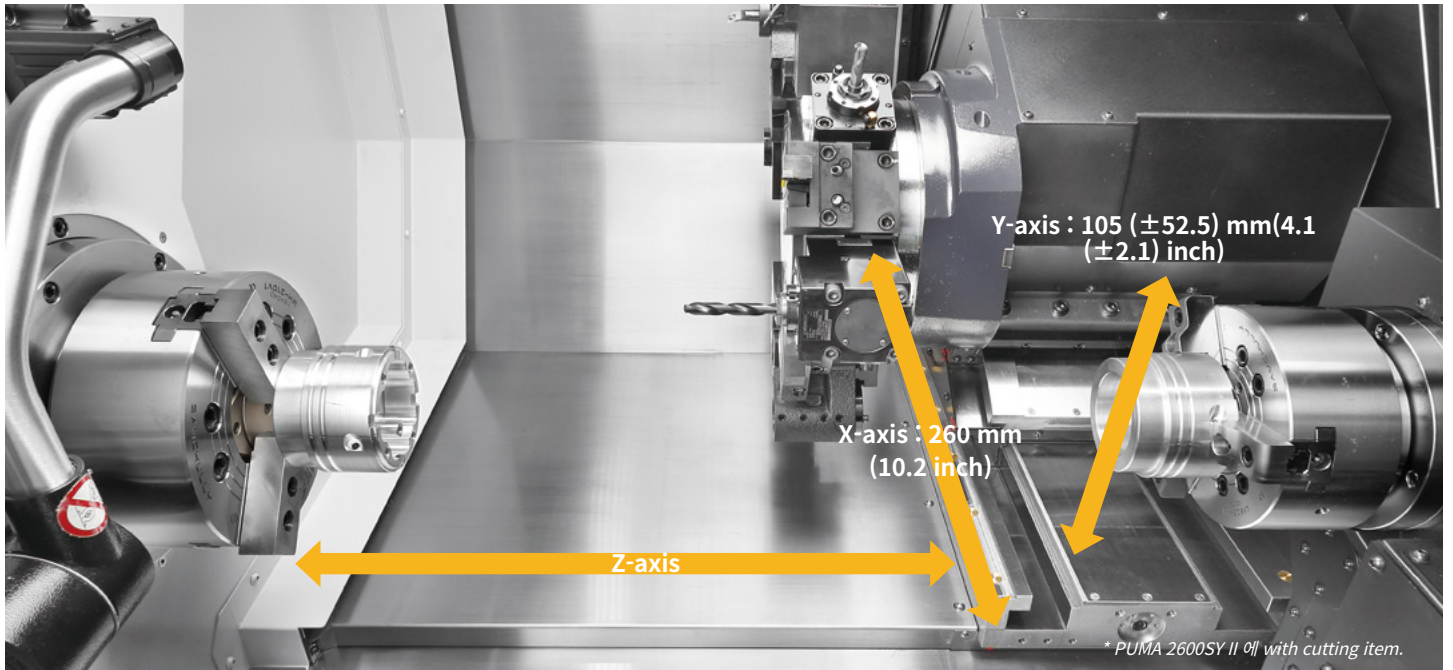

High performance Y-axis for complex machining

Box guideways, applied to all axes, increase rigidity, reduce vibration and ensure powerful and precise machining. The Y-axis enables complex highly accurate shapes and features to be machined quickly and reliably.

Y-axis milling

A wide variety of multi-axis milling operations can be achieved using the Y-axis.

Y-axis milling

PUMA 2100 / 2600Y II series

105 (±52.5) mm
(4.1(±2.1) inch)

Model	Unit	Max. Turning diameter	Max. Turning length	Travel distance (Z-axis)
PUMA 2100Y / SY II	mm (inch)	406 (16.0)	520 (20.5)	590 (23.2)
PUMA 2100LY / LSY II	mm (inch)		760 (29.9)	830 (32.7)
PUMA 2600Y / SY II	mm (inch)	376 (14.8)	760 (29.9)	830 (32.7)
PUMA 2600LY / LSY II	mm (inch)		1280 (50.4)	1350 (53.1)
PUMA 2600YB / SYB II	mm (inch)		725 (28.5)	830 (32.7)
PUMA 2600LYB / LSYB II	mm (inch)		1245 (49.0)	1350 (53.1)

Groove finish cutting using the Y-axis

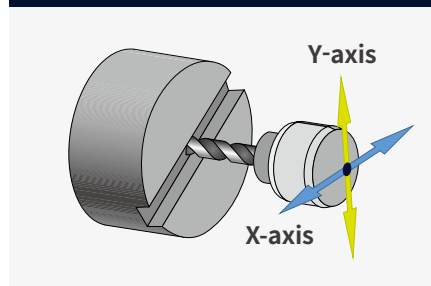

Multi-face cutting

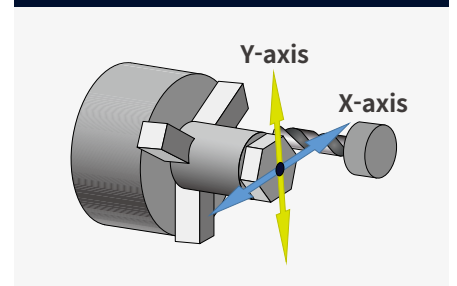

Milling in an eccentric position

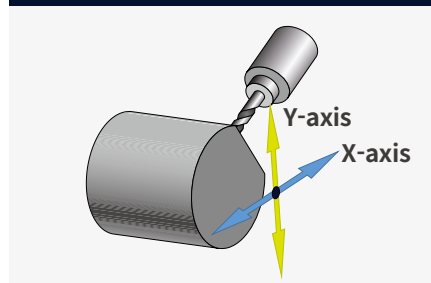

Y & X-axis circular interpolation

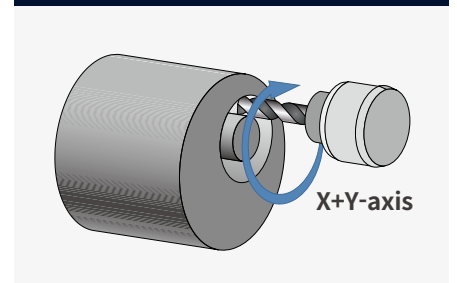

SPINDLE

The high-power/high-torque motor spindle enables high precision and heavy-duty cutting operations to be performed...ensuring improved productivity.

A durable spindle for stable, heavy-duty cutting operations

An enhanced durable spindle featuring redesigned bearings provides increased rigidity.

Model	Driven type	Max. speed r/ min	Max. power kW (Hp)	Max. torque N·m (ft-lbs)
PUMA 2100Y / SY II series	Built-in	5000	22 (29.5)	358 (264.2)
PUMA 2600SY/ sLSY II series	Built-in	4000	22 (29.5)	599 (442.1)
PUMA 2600YB / SYB II series	Belt	2800	26 (34.9)	1123 (828.8)

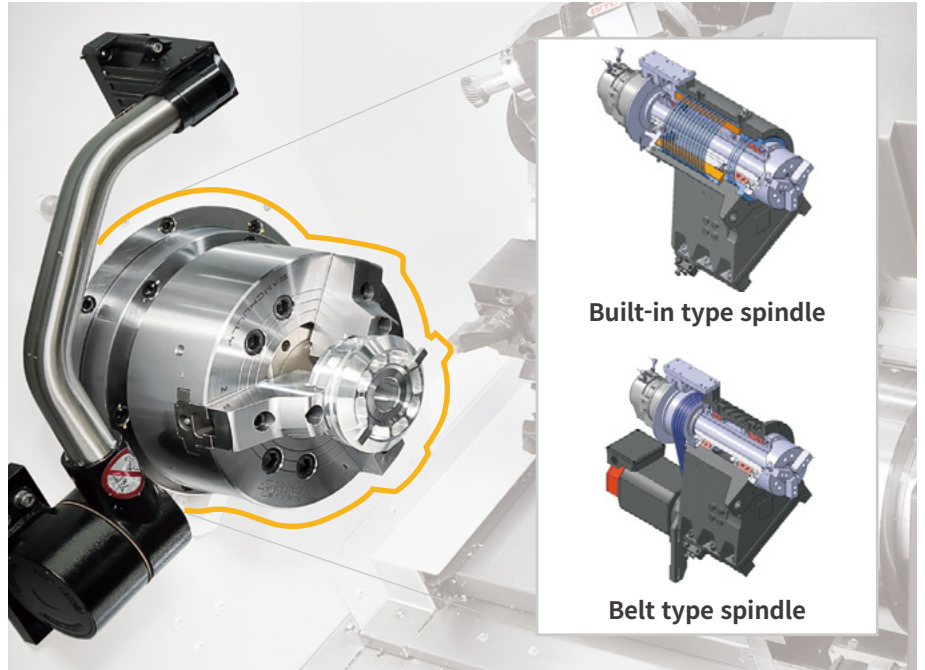

Sub-spindle

The sub-spindle function allows the backends of components to be machined in a single setup.

Model	Driven type	Max. speed r/ min	Max. power kW (Hp)	Max. torque N·m (ft-lbs)
PUMA 2100SY II /LSY II series	6" Built-in	6000 / 5000 <small>OPTION</small>	15 (20.1)	134 (98.9)
PUMA 2600SY /LSY II series	8" Built-in <small>OPTION</small>			
PUMA 2600SYB /LSYB II series	6" Belt* 8" Built-in <small>OPTION</small>	4500 / 5000 <small>OPTION</small>	7.5 / 15	85 / 134

Max. Spindle speed
6000 r/min (Built-in)

Model	Driven type	Max. speed r/ min	Max. power kW (Hp)	Max. torque N·m (ft-lbs)
PUMA 2100SY II /LSY II series	6" Built-in	6000 / 5000 <small>OPTION</small>	15 (20.1)	134 (98.9)
PUMA 2600SY /LSY II series	8" Built-in			
PUMA 2600SYB /LSYB II series	6" Belt*	4500	7.5 (10.1)	85 (62.7)

Improved precision from a highly rigid design

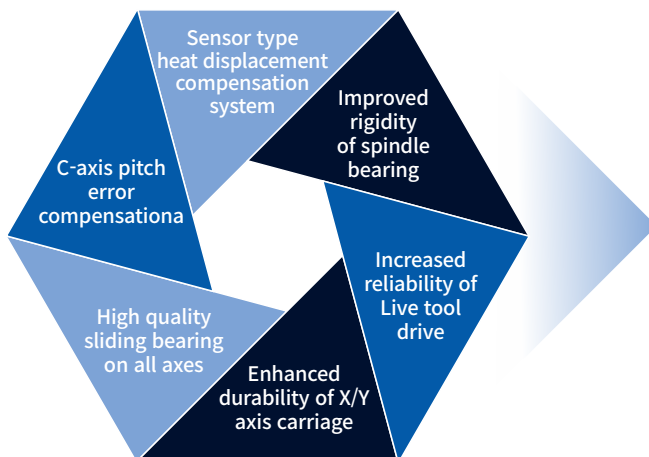

Compared to previous model
Continuous machining accuracy
40 % Improved
Higher C-axis accuracy

TURRET

Turret rotation is controlled by a servo-motor that ensures fast and reliable tool selection. DN Solutions's unique BMT turret design is used on M and Y specification models to enhance heavy-duty milling performance.

New rotary tool drive for greater stability and higher accuracy

The new rotary tool drive with air/oil cooling, low-heat bearings and a clutch function with thermal compensation minimizes thermal displacement and maintains high-precision machining performance even during long periods of operation. Also, when using the 10,000 r/min high-speed milling function (option), both the rotary tool drive and the tool holder are simultaneously cooled via an additional 'Nano cooling' function.

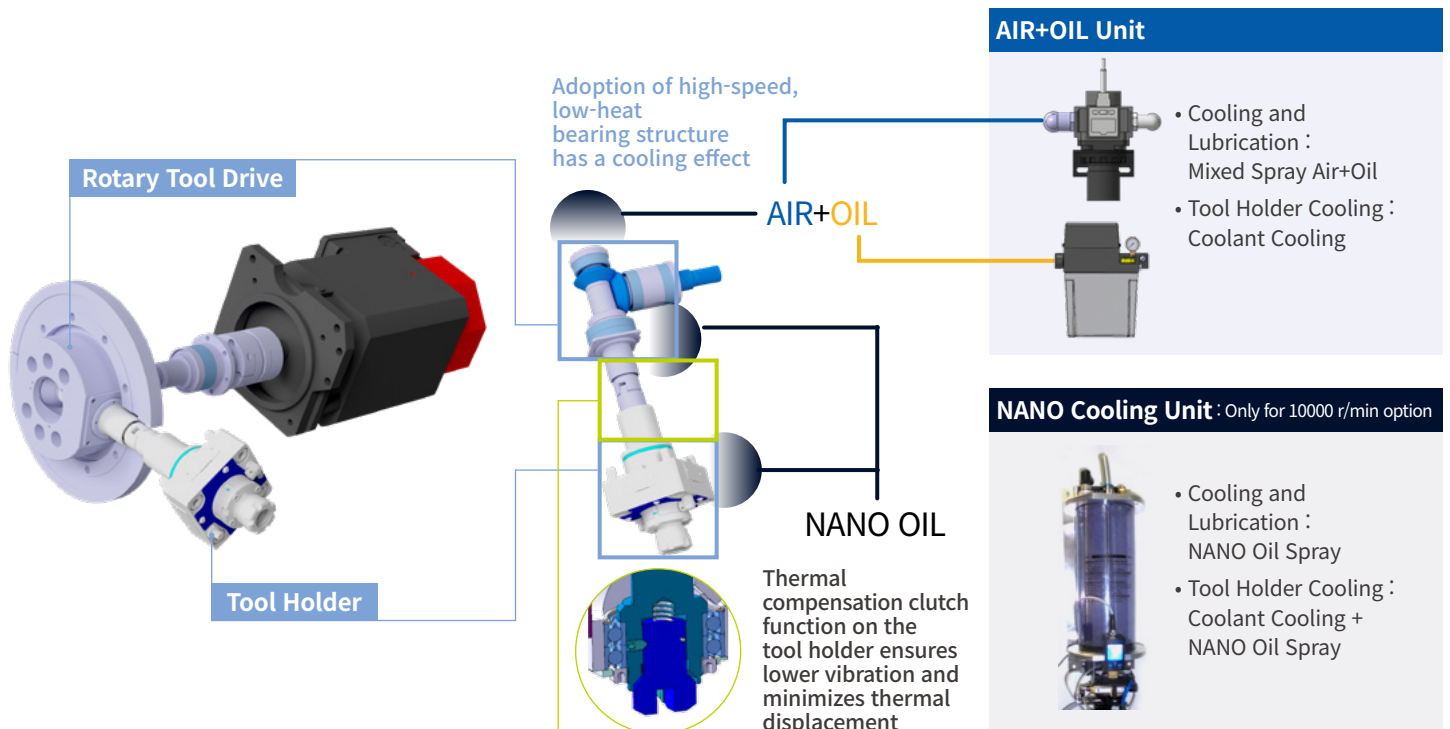

No. of tool stations / Tool type

PUMA 2100Y II series

12st/BMT55P

{12st/BMT55P/24st. indexing, 16st/BMT55P OPTION}

PUMA 2600Y II / YB II series

12st/BMT65P

{12st/BMT65P/24st. indexing OPTION}

Rotary tool spindle power/torque (Fanuc)

PUMA 2100Y II series

5.5 kW/48 N·m

(7.4 Hp/35.4 ft-lbs)

PUMA 2600Y II series

7.5 kW/95 N·m

(10.1 Hp/70.1 ft-lbs)

Rotary tool spindle power/torque (Siemens)

7.79 kW/79.8 N·m

Rotary tool spindle speed

PUMA 2100Y II series

5000 {10000 SO} r/min



TAILSTOCK

A high rigidity hydraulic tailstock clamped to the bed slideway provides stability and support for long workpieces.

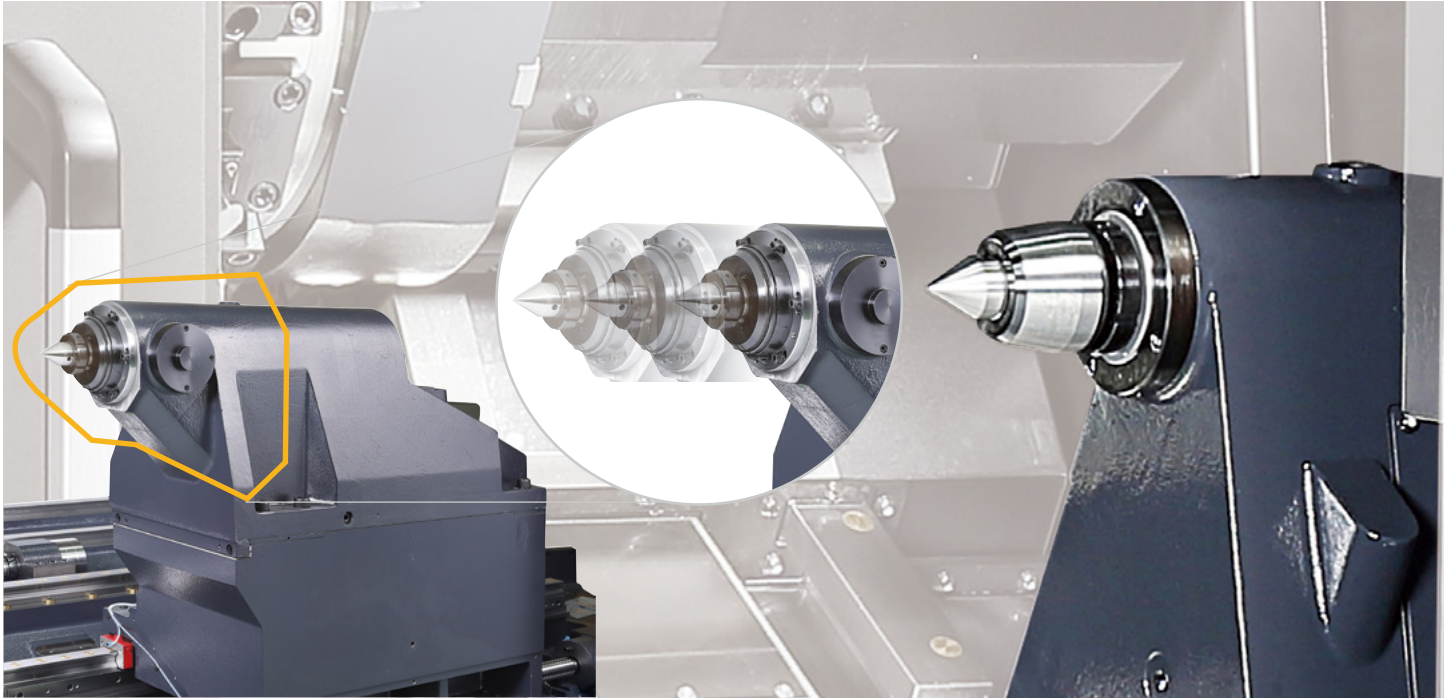

Tailstock type

- Manual
- Programmable
- Servo-driven

Servo-driven tailstock

The servo-driven tailstock makes set-ups faster and easier to complete. The operator inputs the correct M-code information into the control and the tailstock moves to its correct position automatically, via linear motion control of the servo motor and the ball-screw. No manual adjustments are required.

Tailstock EZ function

With the programmable tailstock, the Z-axis position is recorded automatically as the clamped position of tailstock.

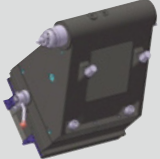
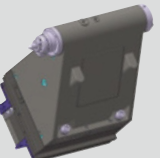
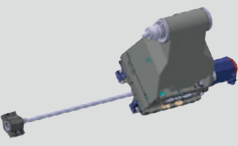
Tailstock type		PUMA 2100Y II / LY II	PUMA 2600Y II / LY II PUMA 2600YB II / LYB II
 Manual	Live center MT4	●	
	Built-in center MT3	○	X
	Live center MT5		●
	Built-in center MT4	X	○
 Programmable	Live center MT4	○	X
	Built-in center MT3		
	Live center MT5	X	○
	Built-in center MT4		
 Servo-driven	Live center MT4	○	X
	Built-in center MT3		
	Live center MT5	X	○
	Built-in center MT4		

STANDARD | OPTIONAL SPECIFICATIONS

A range of options is available to suit individual requirements.

Description	PUMA 2100 / 2600Y II series	PUMA 2100 / 2600SY II series	
Special chucks	△	△	
Soft jaws	●	●	
Dual pressure chucking	○	○	
Hydraulic chuck pressure switch	○	○	
Chuck clamp confirmation	●	●	
Tailstock center : Live center	●	X	
Tailstock center : Dead center	○	X	
Tailstock : Manual	●	X	
Tailstock : Programmable	○	X	
Tailstock : Servo-driven	○	X	
Automatic quill advance & retract	○	X	
6" sub spindle	X	●	
8" sub spindle	X	○	
Tool setter : Manual	○	○	
Tool setter : Automatic_electric	○	○	
Axis-tool number display	●	●	
Structure thermal compensation	●	●	
Auto workpiece measurement	○	○	
Linear scale (X-axis)	○	○	
Linear scale (Z-axis)	○	○	
Linear scale (Y-axis)	○	○	
Feedback system : Absolute position encoder	●	●	
Bar feeder interface	○	○	
Bar puller	△	△	
Workpiece ejector	X	○	
Parts catcher with box	○	○	
Parts catcher with conveyor	○	○	
Workpiece cut off confirmation	X	○	
Automatic front door : with safety device	○	○	
Chip conveyor type : Right side	○	○	
Chip conveyor type : Rear side *1	○	○	
Chip bucket	○	○	
TSC for main / left spindle	○	○	
Oil skimmer	○	○	
Coolant level switch : Sensing level - Low	○	○	
Water soluble Coolant Chiller**	○	○	
Oil mist collector	○	○	
Coolant blower	○	○	
Air blower	○	○	
Air gun	○	○	
Signal tower (yellow, red, green)	○	○	
Gantry loader	△	△	
V-stand for shaft workpiece	○	X	
Quick change tooling(CAPTO)	○	○	
Sketch-turn S/W	○	○	
Customized Special Option	MAIN SPINDLE TSC	SD17568-P2100 II-TSC (PUMA 2100Y II / LY II) SD18582-P2600 II-TSC (PUMA 2600Y II / LY II)	SD17568-P2100 II -TSC (PUMA 2100SY II / LSY II) SD18582-P2600 II -TSC (PUMA 2600SY II / LSY II)
	4 JAW MAIN CHUCK	MHF208 (PUMA 2100Y II / LY II) MHF210 (PUMA 2600Y II / LY II)	MHF208 (PUMA 2100SY II / LSY II) MHF210 (PUMA 2600SY II / LSY II)
	WORKPIECE MEASUREMENT *2	OLP40	

*1 : PUMA 2100/L, PUMA 2600

● Standard ○ Optional X N/A

* Please contact your DN Solutions representative for detailed machine information.

* When using a semi-synthetic type or synthetic type, contact our sales representative or service center in advance.

** Technical consultation is mandatory for the chilling of non-water soluble coolant

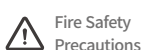

There is a high risk of fire when using non-water-soluble cutting fluids, processing flammable materials, neglecting the controlled and careful use of coolants and modifying the machine without the consent of the manufacturer. Always check the SAFETY GUIDELINES carefully before using the machine.

Steady rest

Steady Rest		PUMA 2100		PUMA 2600	
		Std.	L	Std.	L
Type	Hydraulic	○	○	○	○
	Programmable	○	○	○	○
Size	SLU-1	○	○	○	○
	SLU-2	○	○	○	○
	SLU-B3.1	○	○	○	○
	STA-1	○	○	○	○
	STA-2	○	○	○	○
	AX-1	○	○	○	○
	AX-2	○	○	○	○
	AX-3	○	○	○	○
	AX-4	○	○	○	○
	AX-5*	○	○	○	○

● Standard ○ Optional X N/A

* E-type is unavailable

High pressure coolant

Model		PUMA 2100 / 2600 II series	
		60Hz	50Hz
Standard	1.5 bar	0.4kW x 0.15 Mpa x 60L/min	0.4kW x 0.12Mpa x 40L/min
	4.5 bar	0.75kW x 0.45 Mpa x 30L/min	0.75kW x 0.3 Mpa x 30L/min
Option	7 bar	1.1kW x 0.7 Mpa x 30L/min	1.1kW x 0.5 Mpa x 30L/min
	10 bar*	1.1kW x 1.0 Mpa x 20L/min	1.1kW x 0.7 Mpa x 20L/min
	14.5 bar*	2.2kW x 1.45 Mpa x 35L/min	2.2kW x 1.0 Mpa x 35L/min
Special option	20 bar*	2.2kW x 2.0 Mpa x 30L/min	2.2kW x 2.0 Mpa x 30L/min
	70 bar*	7.5kW x 7.0 Mpa x 29L/min	7.5kW x 7.0 Mpa x 20L/min

* Recommend using coolant chiller.

PERIPHERAL EQUIPMENT

Chip Conveyor OPTION



Long

Short

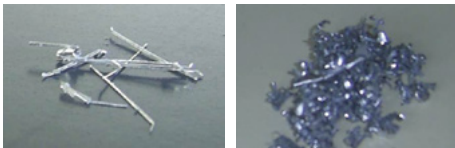

Needle

Sludge

Hinged belt type* : The most common type of chip conveyor. Appropriate for use with steels generating chips of 30mm or more in length.

Drum filter type*** : Chip conveyor with integrated magnet. Appropriate for cast iron workpieces generating fine chips.

Chip conveyor type	Material	Carbon steel			Cast iron		Aluminium		
		Long	Short	Needle	Short	Sludge	Long	Short	Needle
Hinged belt type*		○	△	X	△	X	○	△	X
Drum filter type**	Hinged type	○	△	X	△	X	○	△	X
	Scraper	X	○	△	○	△	X	○	△

● : Suitable, △ : Possible, X : Not suitable

Coolant Chiller (recommended) OPTION

Coolant chiller is highly recommended to prevent temperature increases and to minimize thermal deformation, when using a water-insoluble coolant or a high-pressure coolant system with power over 1.5 kW.

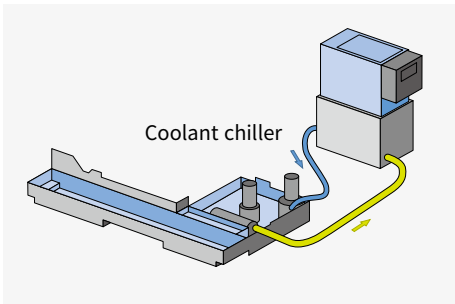

Quick change CAPTO OPTION

The quick change tool system simplifies tool change operations. Recommended for users who need to change tools frequently or to reduce setup times.



Axis-tool number display OPTION

The axis and tool number display provides extra certainty and peace of mind that the correct axis has been selected (before moving to MPG manual mode), and confirmation of the tool (number) being used at any given time.



Optional equipment OPTION

Collet chuck

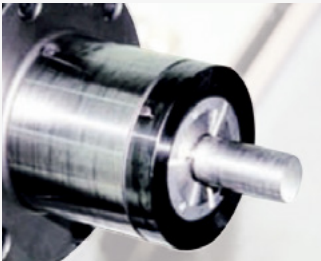

Part catcher

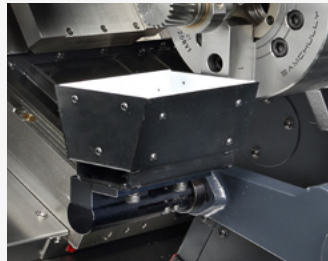

Tool setter



Oil skimmer



Mist collector



Easy-to-clean Coolant Tank



Signal tower



Coolant blower



FANUC i PLUS

DN Solutions Fanuc i Plus maximizes customer productivity and convenience.

15" Screen + New OP

DN Solutions Fanuc i Plus' operation panel enhances operating convenience by incorporating common-design buttons and layout. It features a Qwerty keyboard for fast and easy data input and operation.

DN Solutions Fanuc i Plus

- 15 inch color display
- Intuitive and user-friendly design

USB and PCMCIA card QWERTY keyboard

- EZ-Guide i standard
- Ergonomic operator panel
- 2MB Memory
- Hot keys



iHMI touchscreen OPTION

iHMI provides an intuitive interface that uses a touchscreen for quick and easy operation.

Range of applications

Providing various applications related to planning, machining, improvement and utility, for customer convenience.



SKETCH-TURN OPTION

DN Solutions Conversational programming software for PC

- Easy to learn for beginners
- Time savings in programming
- Reduce processing cycle time



NUMERIC CONTROL SPECIFICATIONS

FANUC

Description	Item	Specifications	Y	SY
			DN Solutions Fanuc i Plus	DN Solutions Fanuc i Plus
Controlled axis	Controlled axes		4(X,Z,C,Y)	6(X,Z,C1,Y,C2,B)
	Simultaneously controlled axes		4 axes	4 axes
Data input/output	Fast data server		○	○
	Memory card input/output		●	●
	USB memory input/output		●	●
	Large capacity memory(2GB)	Note *2) Available Option only with 15" Touch LCD (iHMI Only)	○ *2)	○ *2)
Interface function	Embedded Ethernet		●	●
	Fast Ethernet		○	○
	Enhanced Embedded Ethernet function		●	●
Operation	DNC operation	Included in RS232C interface.	●	●
	DNC operation with memory card		●	●
Program input	Workpiece coordinate system	G52 - G59	●	●
Feed function	AI contour control I	G5.1 Q_, 40 Blocks	●	●
	AI contour control II	G5.1 Q_, 200 Blocks	○	○
Operation Guidance Function	EZ Guidei (Conversational Programming Solution)		●	●
	iHMI with Machining Cycle	Note *1) Only with 15" Touch LCD standard	○*1)	○*1)
	EZ Operation package		●	●
Setting and display	CNC screen dual display function		●	●
Network	FANUC MTConnect		✳	✳
	FANUC OPC UA		✳	✳
Others	Display unit	15" color LCD	●	●
		15" color LCD with Touch Panel	○	○
	Part program storage size & Number of registerable programs	640M(256KB)_500 programs 5120M(2MB)_1000 programs	X ●	X ●

DN SOLUTIONS FANUC i PLUS

EZ-Guide i

Using the DN Solutions EZ-Guide i, users can create a cutting program for any desired shape, including patterns, by entering just the dimensions.

Example programming : Cutting shape

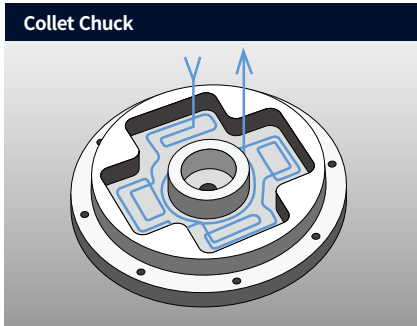
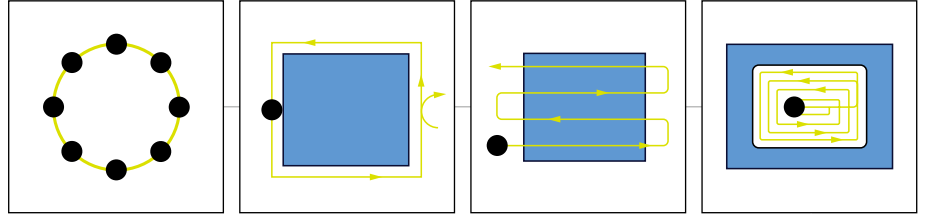

```

O7000 (SAMPLE PROGRAM) ;
...
M3 S1500 ;
G0 X50. Y125. ;
G0 Z30. ;
G1040 T0.5 J3. H0.2 K0.5 ... ;
G1020 H120. V50. U37. W68. ... ;
G0 Z80. ;
M5 ;

```

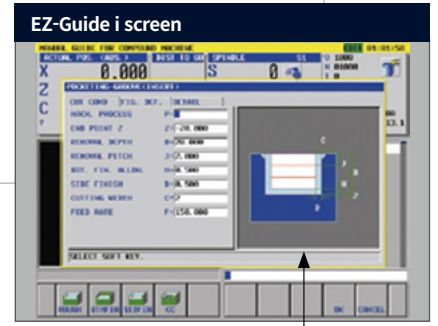

A cutting program is automatically created with the entered values.

Enter the dimensions of the shape

EZ Work

DN Solutions's EZ work supports the user with functions relating to tool data, error diagnostics, set up and machine monitoring.

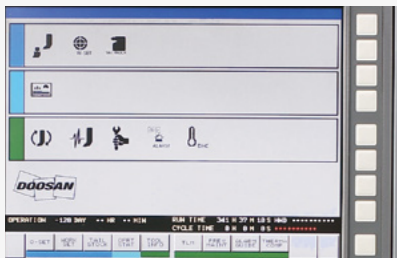

Select menu screen

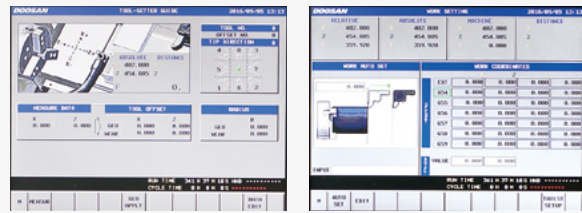

Convenient set up for peripheral equipment

Helps tool setter guide, work setting, tailstock setting, and other measurement and parameter control to reduce setting-up time and facilitates operation.

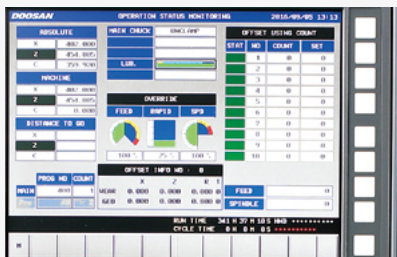

Screen for monitoring the machine and operating conditions

The screen provides a complete view of machine operation information on the feed system position, offset, feedrate and spindle speed, tool life and count in an easy-to-view screen.



Management Convenience Screen

Helps to prepare tools and provides for visual information on alarms to reduce maintenance time.

CONVENIENT OPERATION

Siemens S828D



15.6 inch display + New OP

Siemens 828D' operation panel enhances operating convenience by incorporating common-design buttons and layout. It features a Qwerty keyboard for fast and easy data input and operation.

- 15.6 inch display
- USB (standard)
- QWERTY keyboard

Conversational convenient function

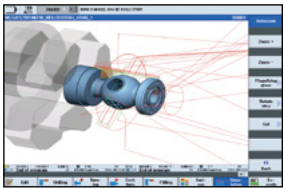

Cutting and operation support function
This function shows a cutting and tool path simulation in real-time.

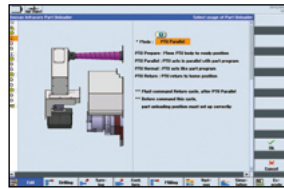

Shop-turn mode
[various]
↓
[attachments]

The automation elements (parts catcher, parts unloader etc.), can be easily controlled via interactive screens.

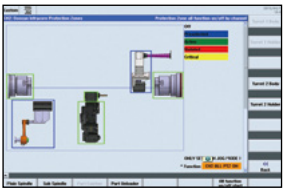

[Custom]
↓
[Protection zones]

Operation safety function
Protection Zone Synchronized Actions checks the interference between the turret and the spindle to prevent collisions caused by operator error.



[offset]
↓
[operating parameter]
↓
[TC service]

Maintenance and service convenience function
Maintenance and service of major equipment and peripheral devices, including the timer and parts counter settings can be easily undertaken.

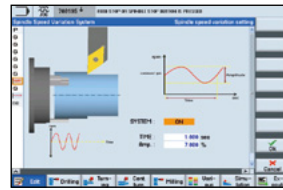

[various]
↓
[attachment]
↓
[DSSV]

Machining accuracy improvement
The NC controls spindle speed at an optimal level for precision threading and turning, making it possible to automatically improve surface roughness.

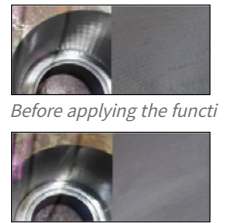

Before applying the function
After applying the function

NUMERIC CONTROL SPECIFICATIONS

SIEMENS

Description	Item	Specifications	Y	SY
			S828D	S828D
Controlled axis	Controlled axes		X,Z,C1,C2,Y	X,Z,C1,C2,Y,C3,B
	Simultaneously controlled axes		4 axes	4 axes
Data input/output	Memory card input/output		X	X
	USB memory input/output		●	●
Interface function	Ethernet (X130)		●	●
	On network drive (without EES option, Extcall)		●	●
Operation	On USB storage medium, e.g. memory stick (without EES option, Extcall)		●	●
	Workpiece coordinate system	G54 - G59, G507 - G599	●	●
Feed function	Advanced surface		X	X
	Top surface		X	X
	Look ahead number of block		1	1
Programming & Editing function	3D simulation, finished part		●	●
	Simultaneous recording		●	●
	DXF Reader for PC integrated in SINUMERIK Operate		○	○
Operation Guidance Function	Shopturn		●	●
Setting and display	Operation via a VNC viewer		●	●
Network	MTConnect		⊕	⊕
	OPCUA		○	○
Others	Part program storage size	Display unit	●	●
		CNC user memory 5MB	●	●
		CNC user memory 100 MB	○	○
		CNC user memory 6GB	X	X
		CNC user memory 40GB (with PCU or IPC)	X	X
		CNC user memory without limit(Execution from external storage devices)(EES / Using by USB or Network)	○	○
HMI user memory for CNC part program 6GB	X	X		

POWER | TORQUE

FANUC

Main Spindle_Built-in

PUMA 2100Y II / SY II series

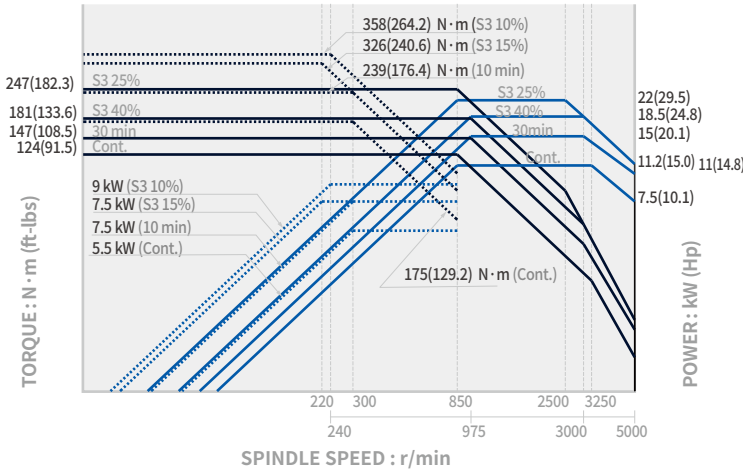

Main Spindle_Built-in

PUMA 2600Y II / SY II series

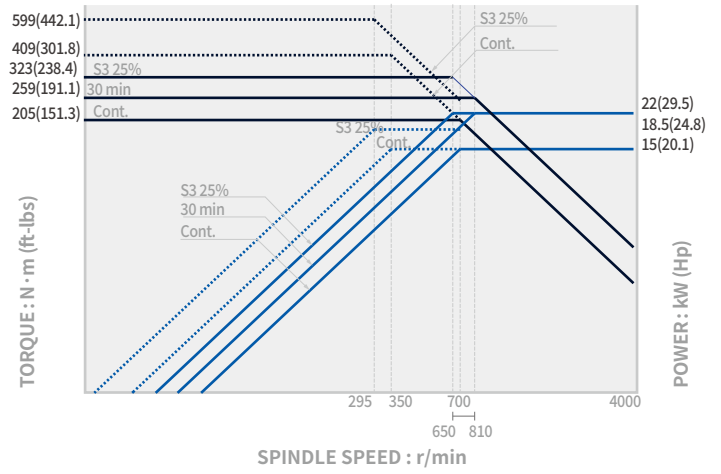

Main Spindle_Belt

PUMA 2600YB II / SYB II series

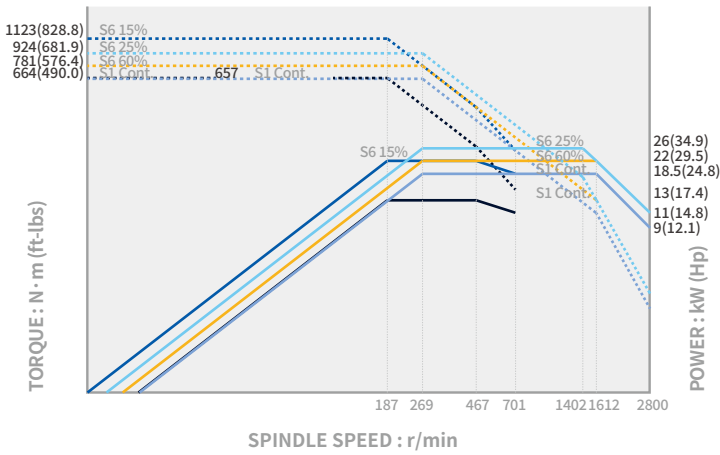

Sub-Spindle_Built-in

PUMA 2100SY II / LSY II series, PUMA 2600SY II / LSY II series

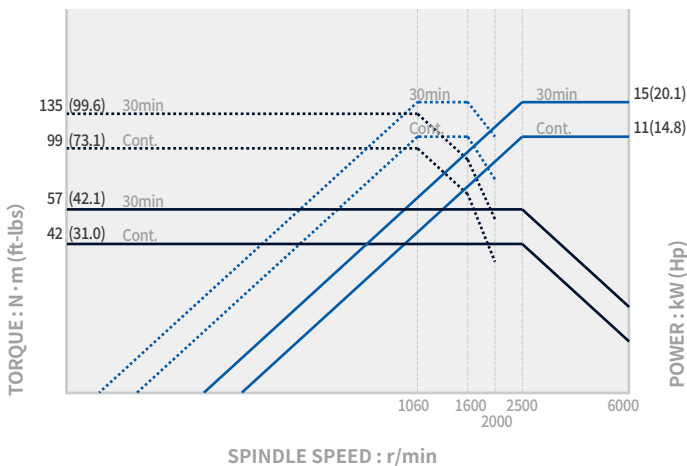

Sub-Spindle_Belt

PUMA 2600SYB II / LSYB II series

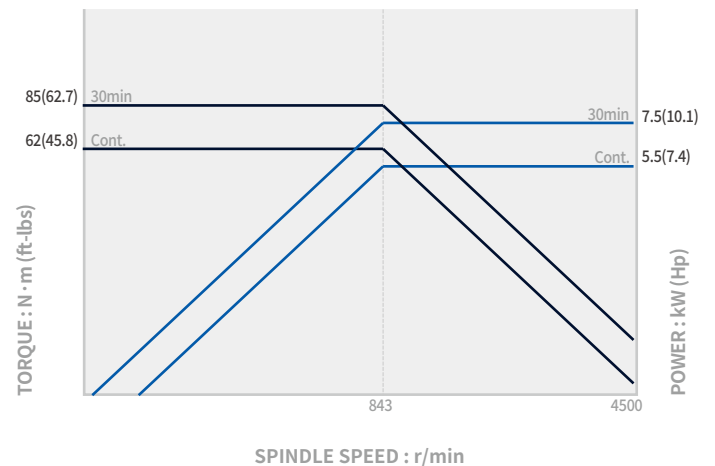

POWER | TORQUE

SIEMENS

Main Spindle_Built-in

PUMA 2100Y II / SY II series

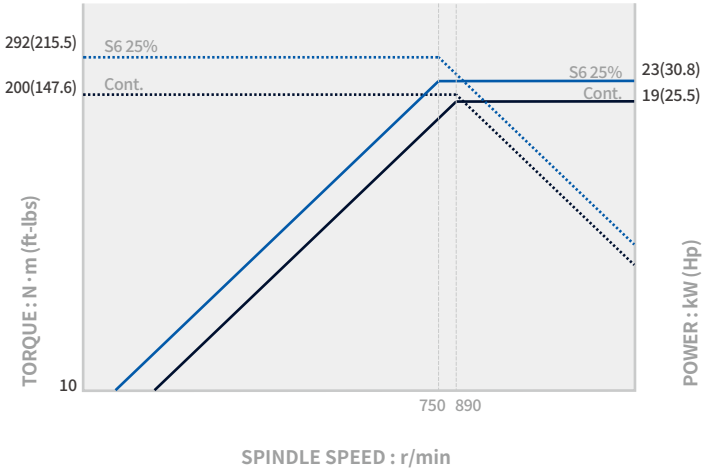

Main Spindle_Built-in

PUMA 2600Y II / SY II series

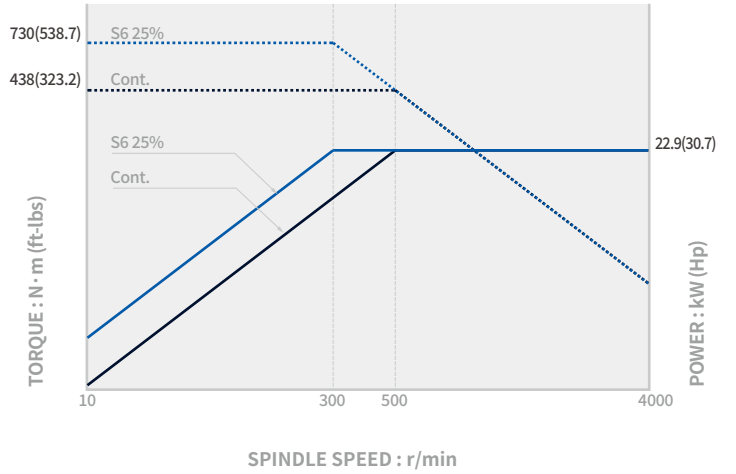

Main Spindle_Belt

PUMA 2600YB II / SYB II series

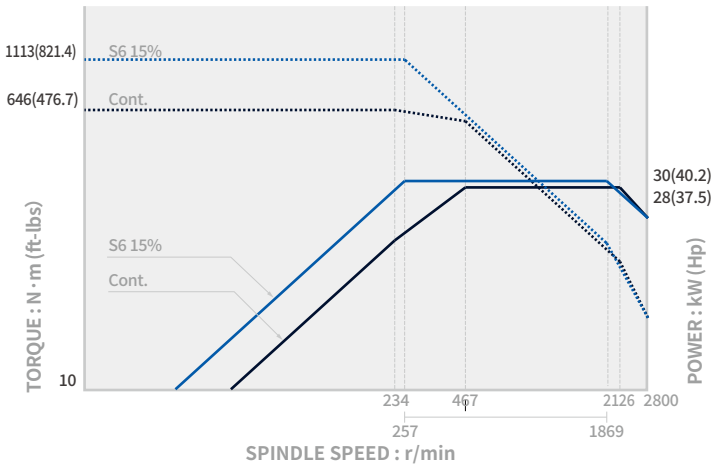

Sub-Spindle_Built-in

PUMA 2600Y II / SY II series

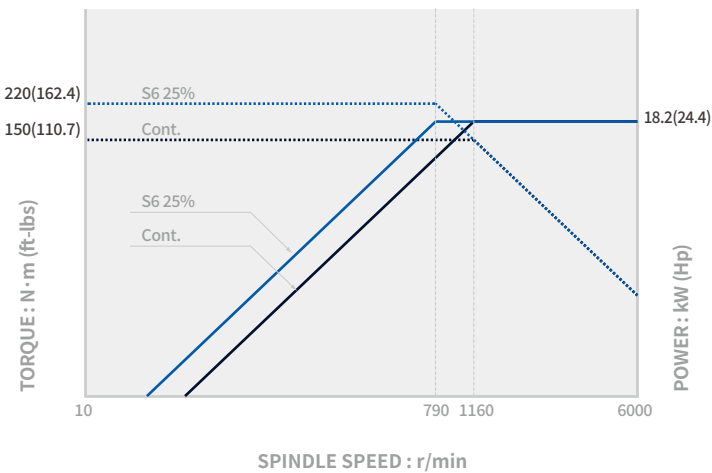

Sub-Spindle_Belt

PUMA 2600SYB II / LSYB II series

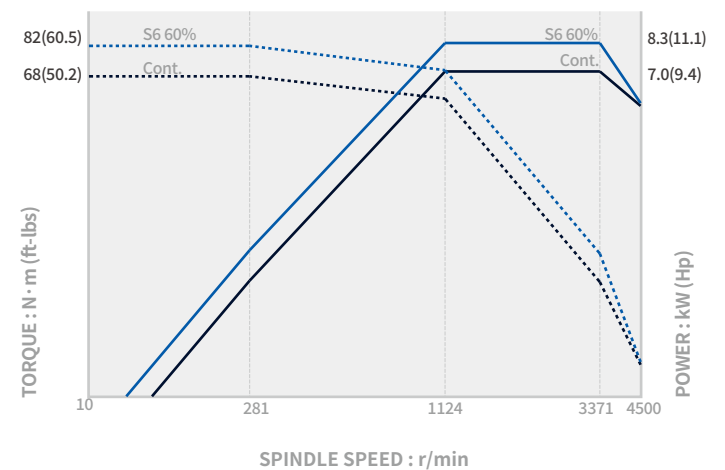

POWER | TORQUE

Rotary tool

Fanuc
PUMA 2100Y II / SY II series

Max. spindle speed
5000 r/min

Max. spindle power
5.5 kW
(7.4 Hp)

Max. spindle torque
48 N·m
(35.4 ft-lbs)

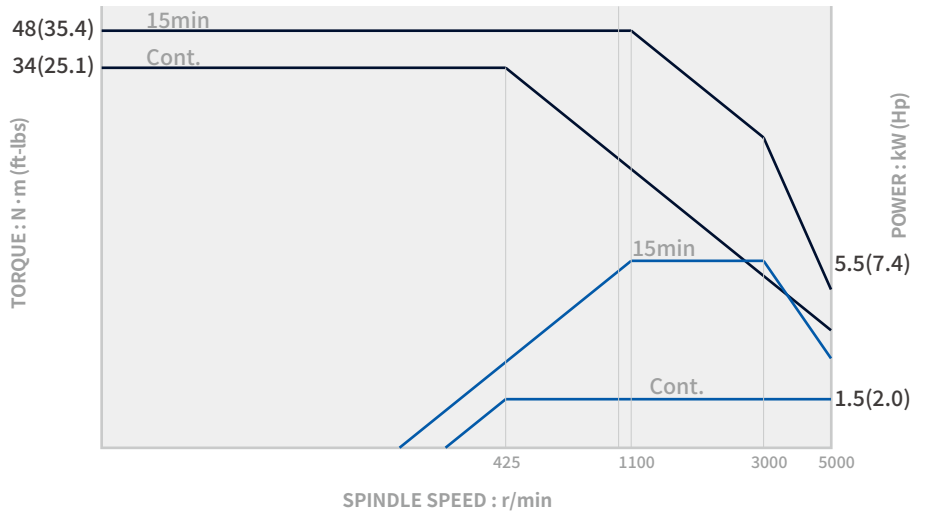

Fanuc
PUMA 2600Y II / SY II / YB II / SYB II series

Max. spindle speed
5000 r/min

Max. spindle power
7.5 kW
(10.1 Hp)

Max. spindle torque
95 N·m
(70.1 ft-lbs)

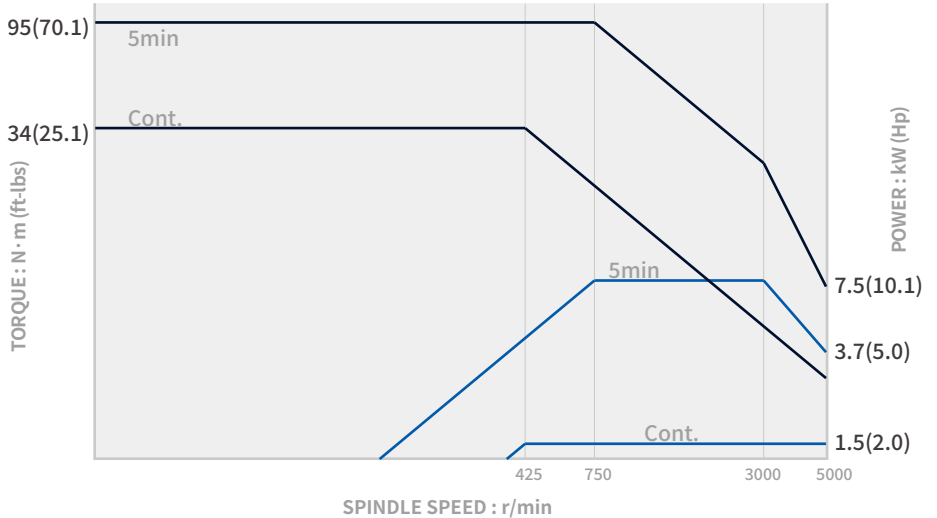

Siemens
PUMA 2100 Y II , 2600Y II / YB II series

Max. spindle speed
5000 r/min

Max. spindle power
7.79/4.1 kW
(10.4/5.5 Hp)

Max. spindle torque
79.8 N·m
(58.9 ft-lbs)

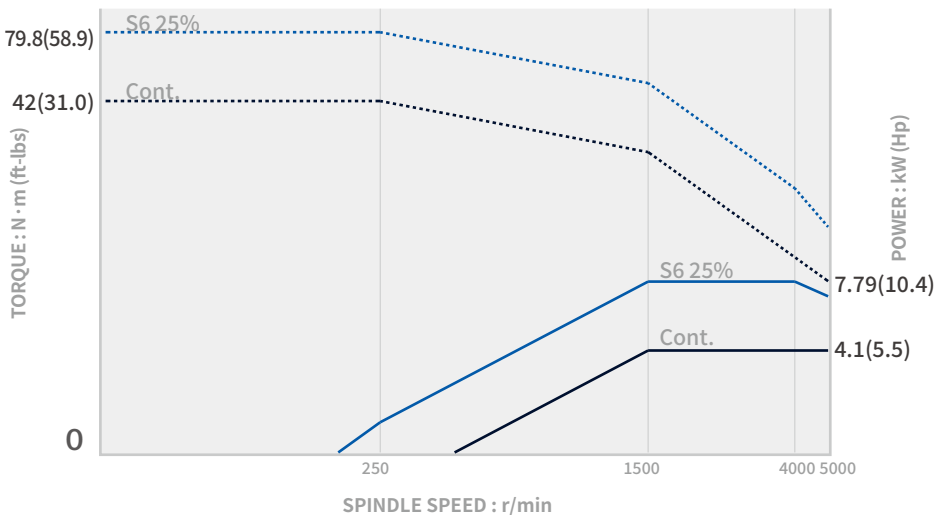

EXTERNAL DIMENSIONS

Unit : mm (inch)

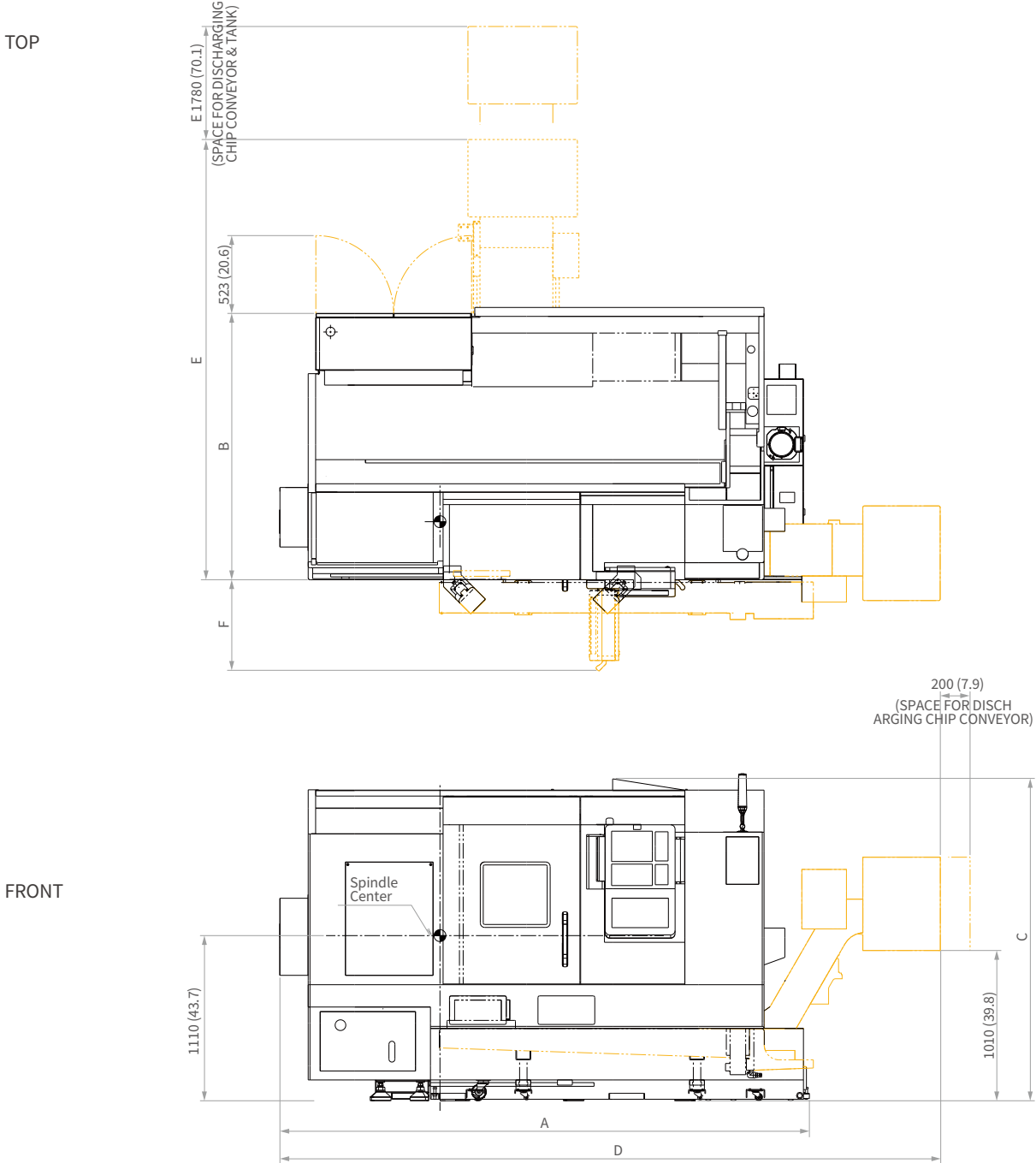

Model	A (Length)	B (Width)	C (Height)	D (Length with side chip conveyor)	E (Width with rear chip conveyor)	F
PUMA 2100Y II / SY II	3190 (125.6)	1945 (76.6)	2163 (85.2)	4070 (160.2)	3074 (121.0)	490 (19.3)
PUMA 2100LY II / LSY II	3410 (134.3)	1945 (76.6)	2163 (85.2)	4290 (168.9)	3074 (121.0)	490 (19.3)
PUMA 2600Y II / SY II	3560 (140.2)	1945 (76.6)	2163 (85.2)	4440 (174.8)	3074 (121.0)	490 (19.3)
PUMA 2600LY II / LSY II	4435 (174.6)	2049 (80.7)	2163 (85.2)	5490 (216.1)	-	545 (21.5)
PUMA 2600YB II / SYB II	3873 (152.5)	1945 (76.6)	2163 (85.2)	4753 (187.1)	3074 (121.0)	490 (19.3)
PUMA 2600LYB II / LSYB II	4438 (174.7)	2049 (80.7)	2163 (85.2)	5492 (216.2)	-	545 (21.5)

MACHINE SPECIFICATIONS

Description		Unit	PUMA 2100Y II / LY II	PUMA 2100SY II / LSY II	PUMA 2600Y II / LY II	
Capacity	Swing over bed	mm (inch)	780 (30.7)	780 (30.7)	780 (30.7)	
	Swing over front door	mm (inch)	680 (26.8)	680 (26.8)	630 (24.8)	
	Swing over saddle*	mm (inch)	630 (24.8)	630 (24.8)	680 (26.8)	
	Recom. Turning diameter	mm (inch)	210 (8.3)	210 (8.3)	255 (10.0)	
	Max. turning diameter	mm (inch)	406 (16.0)	406 (16.0)	376 (14.8)	
	Max. turning length	mm (inch)	520 / 760 (20.5 / 29.9)	520 / 760 (20.5 / 29.9)	760 / 1280 (29.9 / 50.4)	
	Bar working diameter	mm (inch)	65 (2.6)	65 (2.6)	81 {76} (3.2 {3.0})	
Travels	Travel distance	X-axis	mm (inch)	260 (10.2)	260 (10.2)	
		Z-axis	mm (inch)	590 / 830 (23.2 / 32.7)	590 / 830 (23.2 / 32.7)	830 / 1350 (32.7 / 53.1)
		Y-axis	mm (inch)	105 (±52.5) (4.1 (±2.1))	105 (±52.5) (4.1 (±2.1))	105 (±52.5) (4.1 (±2.1))
		B-axis	mm (inch)	-	590 / 830 (23.2 / 32.7)	-
Feedrates	Rapid traverse	X-axis	m/min (ipm)	30 (1181.1)	30 (1181.1)	30 (1181.1)
		Z-axis	m/min (ipm)	30 (1181.1)	30 (1181.1)	30 (1181.1)
		Y-axis	m/min (ipm)	10 (393.7)	10 (393.7)	10 (393.7)
		B-axis	m/min (ipm)	-	30 (1181.1)	-
Spindle	Spindle speed (Belt Type)	r/min	-	-	-	
	Spindle speed (Built-in Type)	r/min	5000	5000	4000	
	Spindle nose		ASA A2-6	ASA A2-6	ASA A2-8	
	Spindle bearing diameter (Front)	mm (inch)	120 (4.7)	120 (4.7)	140 (5.5)	
	Spindle through hole diameter	mm (inch)	76 (3.0)	76 (3.0)	91 (3.6)	
	Min. spindle indexing angle (C-axis)	deg	0.001	0.001	0.001	
Turret	No. of tool stations	st	12 {24 / 16 / 20}*	12 {24 / 16 / 20}*	12 {24 / 16 / 20}*	
	OD tool size	mm (inch)	25 {20 / 25 / 20} (1.0 {0.75 / 1.0 / 0.75}))*	25 {20 / 25 / 20} (1.0 {0.75 / 1.0 / 0.75}))*	25 {20 / 25 / 20} (1.0 {0.75 / 1.0 / 0.75}))*	
	Boring bar diameter	mm (inch)	40 {32 / 40 / 32}* (1.6 {1.3 / 1.6 / 1.3})	40 {32 / 40 / 32}* (1.6 {1.3 / 1.6 / 1.3})	50 {40 / 40 / 32}* (2.0 {1.6 / 1.6 / 1.3})	
	Indexing time (1st swivel time)	s	0.15	0.15	0.15	
	Rotary tool spindle speed	r/min	5000	5000	5000	
Tail stock	Quill diameter	mm (inch)	80 (3.1)	-	100 (3.9)	
	Quill bore taper (Live)		MT#4 {MT#3-Dead}*	-	MT#5 {MT#4-Dead}*	
	Tailstock travel	mm (inch)	590 / 830 (23.2 / 32.7)	-	830 / 1350 (32.7 / 60.2)	
Sub-spindle	Spindle speed	r/min	-	6000 {5000}	-	
	Spindle nose		-	ASA A2-5 {A2-6}	-	
	Spindle bearing diameter (Front)	mm (inch)	-	100 {120} (3.9 {4.7})	-	
	Spindle through hole diameter	mm (inch)	-	62 {76} (2.4 {3.0})	-	
	Min. spindle indexing angle (C-axis)	deg	-	0.001	-	
Motors	Main spindle motor	kW (Hp)	22 / 18.5 / 11 (29.5 / 24.8 / 14.8) (S3 15% / S3 40% / S1 Cont.)	22 / 18.5 / 11 (29.5 / 24.8 / 14.8) (S3 15% / S3 40% / S1 Cont.)	22 / 22 / 15 (29.5 / 29.5 / 20.1) (S3 25% / 30min / S1 Cont.)	
	Sub spindle motor	kW (Hp)	-	15 / 11 (20.1 / 14.8)	-	
	Rotary tool spindle motor	kW (Hp)	5.5 (7.4)	5.5 (7.4)	7.5 (10.1)	
	Coolant pump motor	kW (Hp)	0.4 (0.5)	0.4 (0.5)	0.4 (0.5)	
Power source	Electric power supply (Rated capacity)	kVA	30.7	50.44	41.98	
Machine size	Machine height	mm (inch)	2163 (85.2)	2163 (85.2)	2163 (85.2)	
	Machine dimension	length	mm (inch)	3190 / 3410 (125.6 / 134.3)	3190 / 3410 (125.6 / 134.3)	3560 / 4435 (140.2 / 174.6)
		width	mm (inch)	1945 (76.6)	1945 (76.6)	1945 / 2049 (76.6 / 80.7)
	Machine weight	kg (lb)	5550 / 6050 (12235.5 / 13337.8)	6000 / 6500 (13227.5 / 14329.8)	6100 / 7400 (13448.0 / 16314.0)	
Control	CNC System	-	DN Solutions Fanuc i Plus / SIEMENS 828D			

MACHINE SPECIFICATIONS

Description		Unit	PUMA 2600 Y II / LSY II	PUMA 2600YB II / LYB II	PUMA 2600SYB II / LSYB II	
Capacity	Swing over bed	mm (inch)	780 (30.7)	780 (30.7)	780 (30.7)	
	Swing over front door	mm (inch)	680 (26.8)	680 (26.8)	630 (24.8)	
	Swing over saddle*	mm (inch)	630 (24.8)	630 (24.8)	680 (26.8)	
	Recom. Turning diameter	mm (inch)	255 (10.0)	315 (12.4)	315 (12.4)	
	Max. turning diameter	mm (inch)	376 (14.8)	376 (14.8)	376 (14.8)	
	Max. turning length	mm (inch)	760 / 1280 (29.9 / 50.4)	725 / 1245 (28.5 / 49.0)	725 / 1245 (28.5 / 49.0)	
	Bar working diameter	mm (inch)	81 {76} (3.2 {3.0})	102 (4.0)	102 (4.0)	
Travels	Travel distance	X-axis	mm (inch)	260 (10.2)	260 (10.2)	260 (10.2)
		Z-axis	mm (inch)	830 / 1350 (32.7 / 53.1)	830 / 1350 (32.7 / 53.1)	830 / 1350 (32.7 / 53.1)
		Y-axis	mm (inch)	105 (±52.5) (4.1 (±2.1))	105 (±52.5) (4.1 (±2.1))	105 (±52.5) (4.1 (±2.1))
		B-axis	mm (inch)	830 / 1350 (32.7 / 53.1)	-	830 / 1350 (32.7 / 53.1)
Feedrates	Rapid traverse	X-axis	m/min (ipm)	30 (1181.1)	30 (1181.1)	30 (1181.1)
		Z-axis	m/min (ipm)	30 (1181.1)	30 (1181.1)	30 (1181.1)
		Y-axis	m/min (ipm)	10 (393.7)	10 (393.7)	10 (393.7)
		B-axis	m/min (ipm)	30 (1181.1)	-	30 (1181.1)
Spindle	Spindle speed (Belt Type)	r/min	-	2800	2800	
	Spindle speed (Built-in Type)	r/min	4000	-	-	
	Spindle nose		ASA A2-8	ASA A2-11	ASA A2-11	
	Spindle bearing diameter (Front)	mm (inch)	140 (5.5)	160 (6.3)	160 (6.3)	
	Spindle through hole diameter	mm (inch)	91 (3.6)	115 (4.5)	115 (4.5)	
	Min. spindle indexing angle (C-axis)	deg	0.001	0.001	0.001	
Turret	No. of tool stations	st	12 {24 / 16 / 20}*	12 {24 / 16 / 20}*	12 {24 / 16 / 20}*	
	OD tool size	mm (inch)	25 {20 / 25 / 20} (1.0 {0.75 / 1.0 / 0.75})*	25 {20 / 25 / 20} (1.0 {0.75 / 1.0 / 0.75})*	25 {20 / 25 / 20} (1.0 {0.75 / 1.0 / 0.75})*	
	Boring bar diameter	mm (inch)	50 {40 / 40 / 32}* (2.0 {1.6 / 1.6 / 1.3})	50 {40 / 40 / 32}* (2.0 {1.6 / 1.6 / 1.3})	50 {40 / 40 / 32}* (2.0 {1.6 / 1.6 / 1.3})	
	Indexing time (1st swivel time)	s	0.15	0.15	0.15	
	Rotary tool spindle speed	r/min	5000	5000	5000	
Tail stock	Quill diameter	mm (inch)	-	100 (3.9)	-	
	Quill bore taper (Live)		-	MT#5 {MT#4-Dead}*	-	
	Tailstock travel	mm (inch)	-	830 / 1350 (32.7 / 60.2)	-	
Sub-spindle	Spindle speed	r/min	6000 {5000}	-	4500	
	Spindle nose		ASA A2-5 {A2-6}	-	ASA A2-5 {A2-6}	
	Spindle bearing diameter (Front)	mm (inch)	100 {120} (3.9 {4.7})	-	90 {120} (3.5 {4.7})	
	Spindle through hole diameter	mm (inch)	62 {76} (2.4 {3.0})	-	62 {76} (2.4 {3.0})	
	Min. spindle indexing angle (C-axis)	deg	0.001	-	0.001	
Motors	Main spindle motor	kW (Hp)	22 / 22 / 15 (29.5 / 29.5 / 20.1) (S3 25% / 30min / S1 Cont.)	26 / 22 / 18.5 (34.9 / 29.5 / 24.8) (S6 25% / S6 60% / S1 Cont.)	26 / 22 / 18.5 (34.9 / 29.5 / 24.8) (S6 25% / S6 60% / S1 Cont.)	
	Sub spindle motor	kW (Hp)	15 / 11 (20.1 / 14.8)	-	7.5 / 5.5 (11 / 7)	
	Rotary tool spindle motor	kW (Hp)	7.5 (10.1)	7.5 (10.1)	7.5 (10.1)	
	Coolant pump motor	kW (Hp)	0.4 (0.5)	0.4 (0.5)	0.4 (0.5)	
Power source	Electric power supply (Rated capacity)	kVA	57.08	46.40	54.55	
Machine size	Machine height	mm (inch)	2163 (85.2)	2163 (85.2)	2163 (85.2)	
	Machine dimension	length	mm (inch)	3560 / 4435 (140.2 / 174.6)	3873 / 4438 (152.5 / 174.7)	3873 / 4438 (152.5 / 174.7)
		width	mm (inch)	1945 / 2049 (76.6 / 80.7)	1945 / 2049 (76.6 / 80.7)	1945 / 2049 (76.6 / 80.7)
	Machine weight	kg (lb)	6550 / 7850 (14440.1 / 17306.0)	6200 / 7500 (13668.5 / 16534.4)	6650 / 7950 (14660.5 / 17526.5)	
Control	CNC System	-	DN Solutions Fanuc i Plus / SIEMENS 828D			

* {}: Option * Please contact to specification for SIEMENS 828D

RESPONDING TO CUSTOMERS **ANYTIME, ANYWHERE**

DN SOLUTIONS GLOBAL NETWORK

66 COUNTRIES | **140** + SALES NETWORKS | **3** FACTORIES | **6** REGIONAL HQS



CUSTOMER SUPPORT AND SERVICES

WE'RE THERE FOR YOU WHENEVER YOU NEED US.

We help our customers operate at maximum efficiency by providing them with a range of tried, tested and trusted services - from pre-sales consultancy to post-sales support.



FIELD SERVICES

- On-site service
- Machine installation and testing
- Scheduled preventive maintenance
- Machine repair service



PARTS SUPPLY

- Supplying a wide range of original DN Solutions spare parts
- Parts repair service



TRAINING

- Programming, machine setup and operation
- Electrical and mechanical maintenance
- Applications engineering



TECHNICAL SUPPORT

- Supports machining methods and technology
- Responds to technical queries
- Provides technical consultancy



Head Office

19F, 10, Tongil-ro, Jung-gu, Seoul,
Republic of Korea, 04527

Tel: +82-2-6972-0370
Fax: +82-2-6972-0400

DN Solutions America

360 E State PKWY,
Schaumburg, IL. 60173,
United states

Tel: +1-315-265-7500

DN Solutions Europe

Emdener Strasse 24, D-41540
Dormagen, Germany

Tel: +49-2133-5067-100
Fax: +49-2133-5067-111

DN Solutions India

No.82, Jakkur Village
Yelahanka Hobli,
Bangalore-560064

Tel: +91-80-2205-6900
E-mail: india@dncompany.com

DN Solutions China

Room 101,201,301,
Building 39 Xinzhuan Highway
No.258 Songjiang District
China Shanghai (201612)

Tel: +86 21-5445-1155
Fax: +86 21-6405-1472

DN Solutions Vietnam

M.O.R.E building 2F, 40A-40B Ut
Tich Street, 04 Ward 04,
District Tan Binh District,
Ho Chi Minh City, Vietnam

Tel: +84 28-7304-0163

DN Solutions Mexico

Avenida Parque Bicentenario
#100 Nave M65L3-6,
Fraccionamiento San Isidro
Business Park,
Santa Rosa Jauregui,
Querétaro, México

E-mail: efrain.figueroa@dncompany.com

Sales inquiry

sales@dncompany.com